

Lesson 13: The Formulas for Volume

Classwork

Example 1

Determine the volume of a cube with side lengths of $2\frac{1}{4}$ cm.

Example 2

Determine the volume of a rectangular prism with a base area of $\frac{7}{12}$ ft² and a height of $\frac{1}{3}$ ft.

Exercises

- Use the rectangular prism to answer the next set of questions.
 - Determine the volume of the prism.

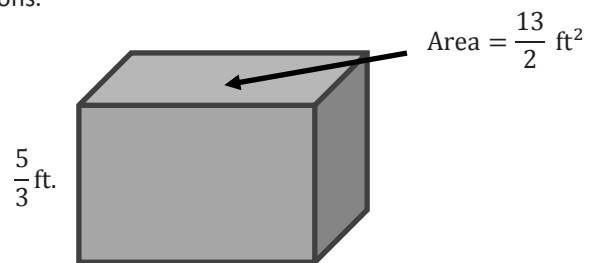

- Determine the volume of the prism if the height of the prism is doubled.

- c. Compare the volume of the rectangular prism in part (a) with the volume of the prism in part (b). What do you notice?
- d. Complete and use the table below to determine the relationship between the height and volume.

Height in Feet	Volume in Cubic Feet
$\frac{5}{3}$	$\frac{65}{6}$
$\frac{10}{3}$	$\frac{130}{6}$
$\frac{15}{3}$	
$\frac{20}{3}$	

What happened to the volume when the height was tripled?

What happened to the volume when the height was quadrupled?

What conclusions can you make when the base area stays constant and only the height changes?

- 2.
- a. If B represents the area of the base and h represents the height, write an expression that represents the volume.
- b. If we double the height, write an expression for the new height.

- c. Write an expression that represents the volume with the doubled height.
- d. Write an equivalent expression using the commutative and associative properties to show the volume is twice the original volume.
3. Use the cube to answer the following questions.

- a. Determine the volume of the cube.

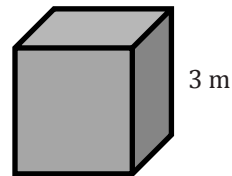

- b. Determine the volume of a cube whose side lengths are half as long as the side lengths of the original cube.
- c. Determine the volume if the side lengths are one-fourth as long as the original cube's side lengths.
- d. Determine the volume if the side lengths are one-sixth as long as the original cube's side length.
- e. Explain the relationship between the side lengths and the volumes of the cubes.

4. Check to see if the relationship you found in Exercise 3 is the same for rectangular prisms.



- a. Determine the volume of the rectangular prism.
- b. Determine the volume if all of the sides are half as long as the original lengths.
- c. Determine the volume if all of the sides are one-third as long as the original lengths.
- d. Is the relationship between the side lengths and the volume the same as the one that occurred in Exercise 3? Explain your answer.

- 5.
- If e represents an edge length of the cube, create an expression that shows the volume of the cube.
 - If we divide the edge lengths by three, create an expression for the new edge length.
 - Write an expression that represents the volume of the cube with one-third the side length.
 - Write an equivalent expression to show that the volume is $\frac{1}{27}$ of the original volume.

Problem Set

1. Determine the volume of the rectangular prism.

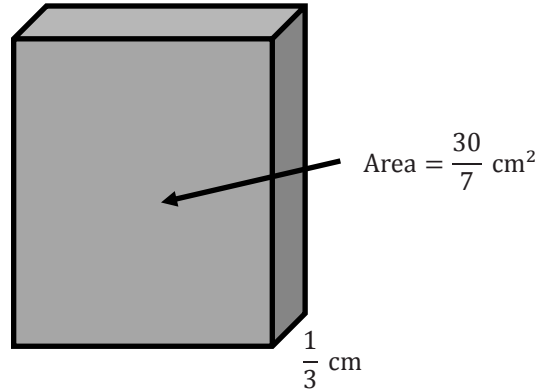

2. Determine the volume of the rectangular prism in Problem 1 if the height is quadrupled (multiplied by four). Then, determine the relationship between the volumes in Problem 1 and this prism.
3. The area of the base of a rectangular prism can be represented by B , and the height is represented by h .
- Write an equation that represents the volume of the prism.
 - If the area of the base is doubled, write an equation that represents the volume of the prism.
 - If the height of the prism is doubled, write an equation that represents the volume of the prism.
 - Compare the volume in parts (b) and (c). What do you notice about the volumes?
 - Write an expression for the volume of the prism if both the height and the area of the base are doubled.
4. Determine the volume of a cube with a side length of $5\frac{1}{3}$ in.
5. Use the information in Problem 4 to answer the following:
- Determine the volume of the cube in Problem 4 if all of the side lengths are cut in half.
 - How could you determine the volume of the cube with the side lengths cut in half using the volume in Problem 4?

6. Use the rectangular prism to answer the following questions.

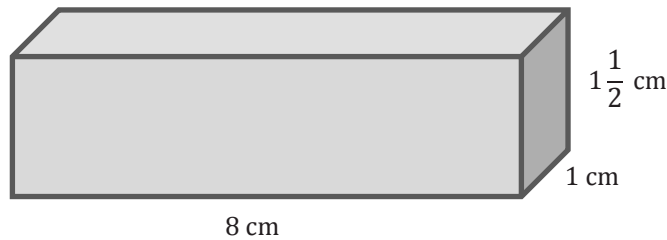

a. Complete the table.

Length	Volume
$l = 8 \text{ cm}$	
$\frac{1}{2}l =$	
$\frac{1}{3}l =$	
$\frac{1}{4}l =$	
$2l =$	
$3l =$	
$4l =$	

- b. How did the volume change when the length was one-third as long?
 - c. How did the volume change when the length was tripled?
 - d. What conclusion can you make about the relationship between the volume and the length?
7. The sum of the volumes of two rectangular prisms, Box A and Box B, are 14.325 cm^3 . Box A has a volume of 5.61 cm^3 .
- a. Let B represent the volume of Box B in cubic centimeters. Write an equation that could be used to determine the volume of Box B.
 - b. Solve the equation to determine the volume of Box B.
 - c. If the area of the base of Box B is 1.5 cm^2 , write an equation that could be used to determine the height of Box B. Let h represent the height of Box B in centimeters.
 - d. Solve the equation to determine the height of Box B.