

Lesson 24: Surface Area

Classwork

Example 1

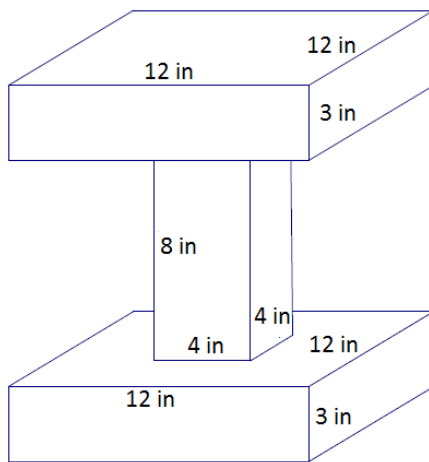

Example 2

- a. Determine the surface area of the cube.

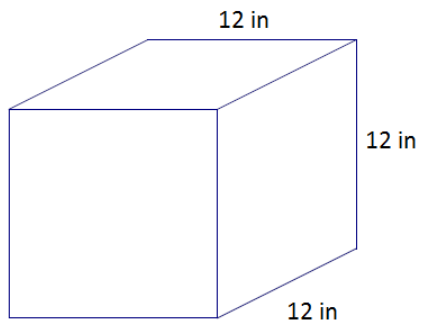

- b. A square hole with a side length of $\frac{1}{2}$ inches is drilled through the cube. Determine the new surface area.

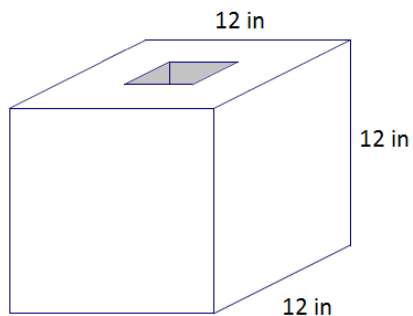

Example 3

A right rectangular pyramid has a square base with a side length of 10 inches. The surface area of the pyramid is $150\sqrt{3}$ in². Find the height of the four lateral triangular faces.

Exercises 1–8

1. Determine the surface area of each figure. Assume all faces are rectangles unless it is indicated otherwise.

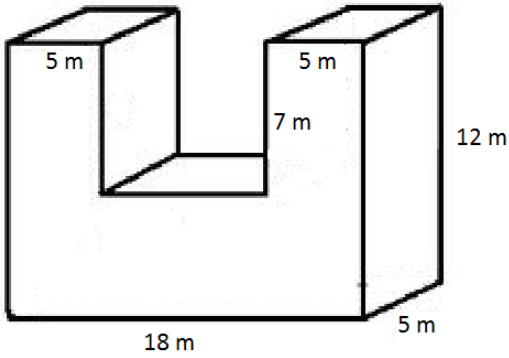

2. In addition to your calculation, explain how the surface area was determined.

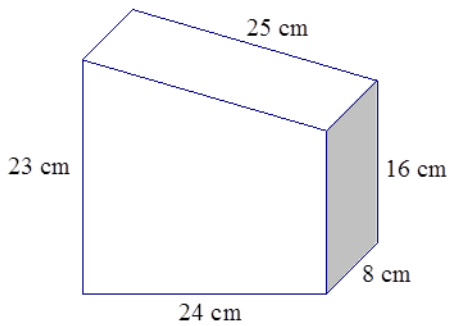

3.

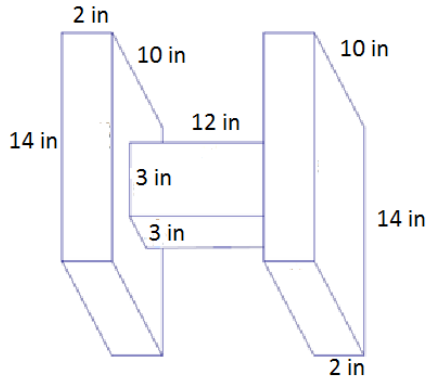

4. In addition to your calculation, explain how the surface area was determined.

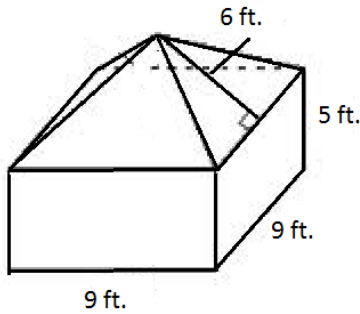

5. A hexagonal prism has the following base and has a height of units. Determine the surface area of the prism.

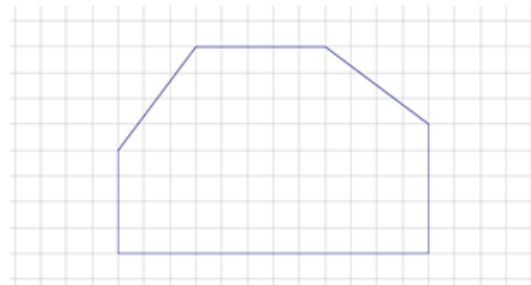

6. Determine the surface area of each figure.

a.

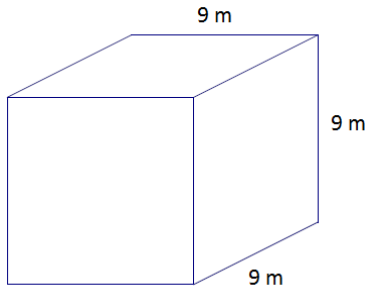

b. A cube with a square hole with 3 m side lengths has been drilled through the cube.

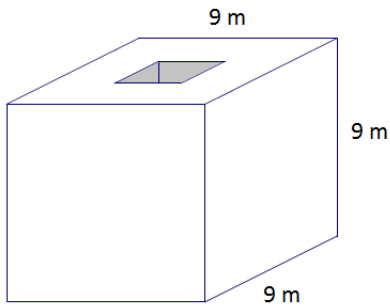

c. A second square hole with 3 m side lengths has been drilled through the cube.

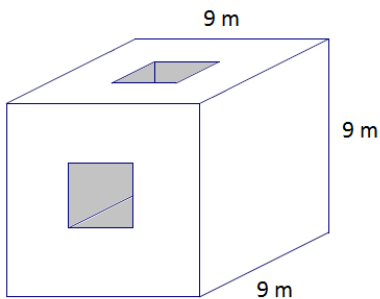

7. The figure below shows _____ cubes with an edge length of _____ unit. Determine the surface area.

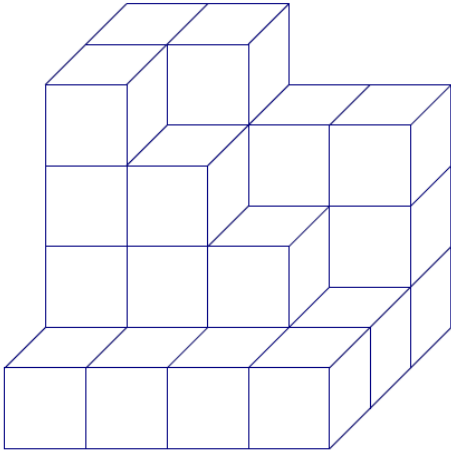

8. The base rectangle of a right rectangular prism is _____ ft. _____ ft. The surface area is _____ ft^2 . Find the height.
Let _____ be the height in feet.

Problem Set

Determine the surface area of each figure.

- In addition to the calculation of the surface area, describe how you found the surface area.

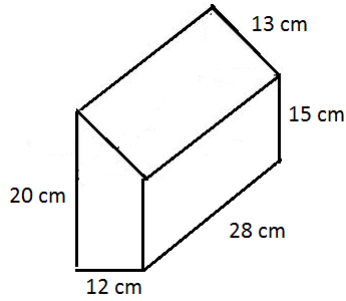

-
-

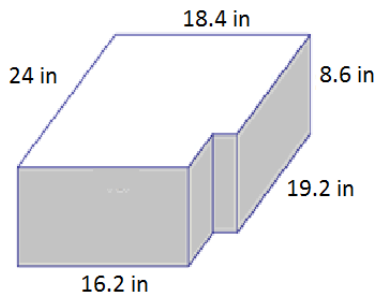

-
-
-

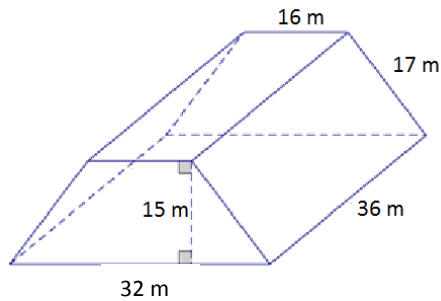

4. Determine the surface area after two square holes with a side length of 5 m are drilled through the solid figure composed of two rectangular prisms.

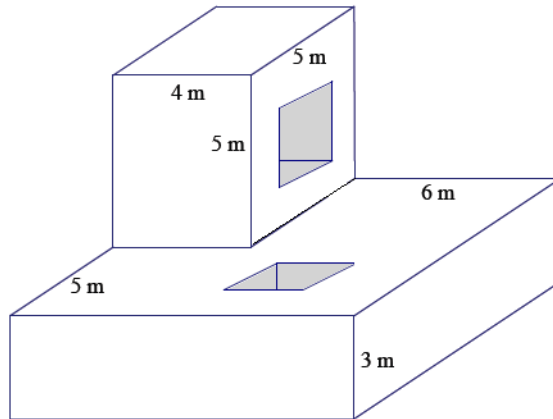

5. The base of a right prism is shown below. Determine the surface area if the height of the prism is 5 cm . Explain how you determined the surface area.